

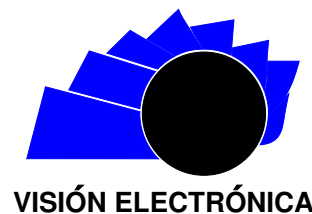

Visión Electrónica

Más que un estado sólido

<https://doi.org/10.14483/issn.2248-4728>



A CASE-STUDY VISION

Automated greenhouse, instrumentation and fuzzy logic

Invernadero automatizado, instrumentación y lógica difusa

Sergio Alejandro Vaca-Vargas ¹

INFORMACIÓN DEL ARTÍCULO

Historia del artículo:

Enviado: 19/11/2019

Recibido: 08/12/2019

Aceptado: 27/01/2020

Keywords:

Control

Crop

Fuzzy logic

Greenhouse

Instrumentation

Microclimate



Palabras clave:

Control

Cultivo

Lógica difusa

Invernadero

Instrumentación

Microclimas.

ABSTRACT

Crops are vulnerable to climatic conditions, and their quality varies according to environmental behaviours. Under optimal conditions, crops can enjoy good productive development with increases in yield per unit area while reducing risks of climate, pests and disease. Using electronic instrumentation, it becomes possible to make efficient use of greenhouse resources by controlling them according to each stage of crop development. In an isolated environment, such as a greenhouse, it also becomes possible to carry out production at any time of the year, thanks to microclimates. This paper presents an automated greenhouse prototype that uses fuzzy-logic electronic instrumentation to control its irrigation, lighting, humidification and ventilation systems.

RESUMEN

Los cultivos son susceptibles a condiciones climáticas, por ende, la calidad de los mismos puede variar según el comportamiento ambiental. Bajo condiciones óptimas el cultivo puede tener un buen desarrollo productivo y un aumento en el rendimiento por unidad de superficie, reduciendo los riesgos causados por cambios climatológicos, plagas y enfermedades. Con la aplicación de electrónica en invernaderos es posible hacer uso eficiente de los recursos ya que se pueden controlar según cada etapa fenológica del cultivo. Al estar en un ambiente aislado, es decir independiente del medio exterior, es posible realizar producción en cualquier época del año, lo anterior gracias a los microclimas. El siguiente artículo muestra el desarrollo de un invernadero automatizado haciendo uso de instrumentación electrónica para controlar mediante lógica difusa sus sistemas de riego, luz, humidificación y ventilación.

¹BSc. in Automation engineering, Universidad de La Salle, Colombia. MSc. (c). In Agricultural Engineering and Biosystems, Universidad Nacional de Colombia, Colombia. E-mail: svacav@unal.edu.co.

1. Introduction

At present, crops greatly depend on fluctuating climatic variables. Therefore, quality can vary, causing inefficiency and increasing costs. To mitigate risks, it is necessary to use automated systems to adequately control different variables inside greenhouse microclimates [1–5]. The automation of greenhouses has been advanced to maintain solar radiation energy, protect the produce and provide suitable environments for growth.

Humidity and temperature can be passively controlled using zenithal openings, efficient enclosure types, green construction materials, nebulizers, fans and heaters [5, 6]. Lighting is controlled via incandescent lamps, fluorescent bulbs, light-emitting diodes (LED), electroluminescents, etc. Ventilation is used to control CO₂ levels, and airflow is used to maintain uniformity of temperature, humidity and air composition.

Simply measuring these variables is not enough; it is also necessary to actively control them. For this purpose, classic proportional, integral and derivative control methods are used, and newer predictive and adaptive neural networks, genetic algorithms and fuzzy control methods have been implemented.

1.1. Greenhouse solution

Our team developed a scale prototype of a Venlo greenhouse (see Figure 1) that adopts fuzzy logic to monitor and control some of the systems that influence crop production (i.e. irrigation, lighting, humidification and ventilation systems). Apart from being a low energy solution, it is affordable and efficient. This paper provides an overview of the prototype's development, its implementation, general failures and possible improvements.

Figure 1: Automated greenhouse.



Source: own

At industrial levels, automation is of great significance. However, this application is quite suitable for home and amateur use. The system uses a central computer with connected sensors that collect variable metrics with respect to initially programmed thresholds. The systems, in turn, are connected to the fertigation and climate regulation sub-systems. Various sensors or automatisms are distributed in the sub-systems, each one autonomous. In the central controller, the information captured by the sensors is collected, the actions are coordinated and change orders are sent to the different sub-systems.

2. Theoretical framework

Fuzzy logic is used worldwide for various mass-production applications. For this reason, developing countries, such as Colombia, must continue to advance these ideas, especially in agriculture. This project resulted in a Venlo greenhouse prototype that facilitates monitoring and control of measurable plant variables, making it suitable for small-yield low-aromatic plants. There are currently numerous greenhouse automation systems on the market. Innovations include the automation of vent openings, radiometers for luminosity degree, heating equipment and more. The most relevant parameters to this study are those that relate to climate, irrigation, CO₂ and humidity.

2.1. Structure types

Greenhouse structures vary according to the characteristics of their purpose. Passive types enable low energy consumption for heating and easy maintenance. They can employ high technological innovations, but they are designed to take advantage of the natural regional light and climate.

Autochthonous greenhouses are built by workers experienced in the use of local materials and the application of the local zone's climate, and this method predominates current scientific and technical rationality. Wood is the most widespread structural element, and polyethylene film having different optical and mechanical properties is the covering material of choice. [1] This type of structure has disadvantages of low light transmission, especially in structures having low sloped roofs. Ventilation is often inefficient, owing to the reduced window-surface area and type (e.g. rolled plastic). Additionally, during cold periods, excess moisture often results in dripping condensation or even interior rainfall. [1].

Industrial greenhouses include a great variety of structures generally built of galvanized steel. However, those having attached ships of multi-tunnel arched structures are predominant. See Figure 2. The roof cover is made of plastic film, whereas the fronts and sides can be built with semi-rigid plastic sheets, based on the available polycarbonate. [1] This structure has the disadvantage of condensation accumulating atop the arc, where it is difficult to remove. This reduces light transmission, and it drips uncontrollably onto the crop. Some designs have mitigated this problem, but it has not been completely solved. Another problem is that ventilation efficiency deteriorates when insects cover the window screens. [1].

Figure 2: Industrial greenhouse.



Source: own

Glass-covered greenhouses are typically used in cold climates. The Dutch Venlo is the most common variety. These are usually built in masse to reduce installation costs and to save energy. Technically, this greenhouse is structurally excellent. Most use discontinuous roof windows without lateral ventilation. However, in very cold environments, ventilation should be adopted. See Figure 3.

In warmer areas, roof windows are recommended to extend along the length of the greenhouse. It is also necessary to combine zenithal and lateral ventilation, particularly in light windy conditions.

2.2. Irrigation systems

Drip Irrigation comprises a network of interconnected pipes having small holes located at the foot of the plants. See Figure 4. Water circulates through the network and drips through the holes according to a programmed speed of opening and closing an entry valve. This system is controlled by a computer program that manages the duration and timing of the irrigation.

Figure 3: Glass-covered greenhouse.



Source: own

Figure 4: Drip irrigation.



Source: own

It is possible to adapt different types of sprinklers or drippers to the hose, and the hoses can easily be extended.

Sprinkler Irrigation comprises pipes and sprinklers that function as a kind of localized rain. See Figure 5. Sprinklers have control elements (e.g. regulating valves) that limit water flow and control irrigation pressure. Stationary sprinklers obviously do not move, but mobile sprinklers do (or they can be moved). Micro-sprinklers project water onto the ground in the form of a mist.

Figure 5: Sprinkler irrigation.

Source: own

2.3. Climate control

For greatest results, factors of temperature, relative humidity, light and CO₂ must be managed within minimum and maximum limits. Doing so helps ensure

plants convert energy, metabolize and produce [3]. Environmental controls are used to properly managing greenhouse heating, ventilation and fertilization systems. See Figure 6.

Figure 6: Climate control.

Source: own

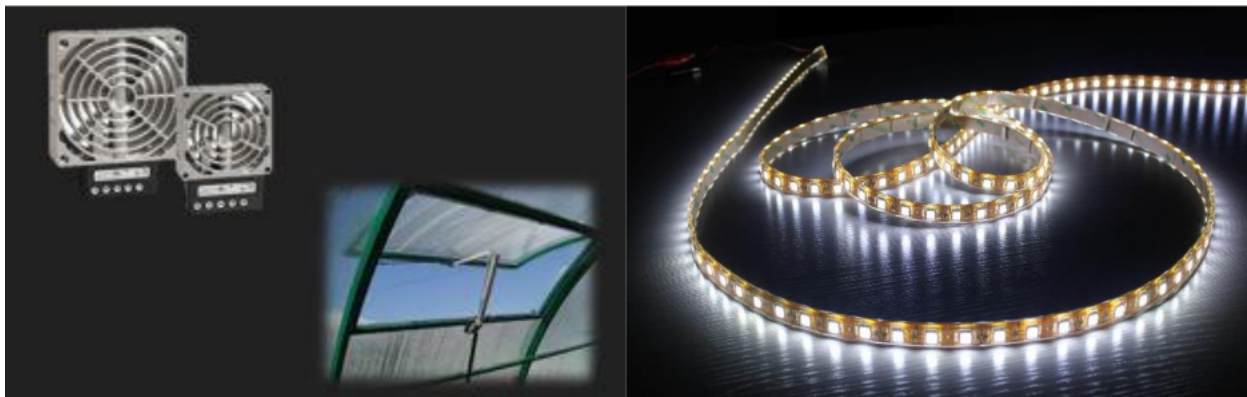
Figure 7: Temperature and light actuators.

Source: own

Sensors and actuators acquire these measurable variables, depending on the physical principles of the greenhouse. Thus, there are different implementations of varying costs. Thermocouples, thermo-cameras and humidity sensors are recommended to handle the environmental temperature to ensure a range of 10–90% humidity. Several control techniques are applied to manipulate actuators to account for air temperature, plant transpiration and evaporation. These sometimes apply electric heaters, which are used to raise temperatures in local areas, or fans to cool the air, such as in the case when solar radiation is applied. See Figure 7. Fan technologies vary according to their size, shape

and efficiency, and the intensity, color and temperature of the light can be detected using a light-dependent resistor (LDR).

2.4. Fuzzy logic

Fuzzy logic was developed to account for the idea that the elements upon which human thought are built are not numbers but are instead linguistic labels. This is because our knowledge can be quantized in terms lacking well-defined boundaries. Linguistic tags, thus, can generate far more useful information for our benefit. An example can be seen in Figure 8.

Figure 8: First fuzzy-logic example.

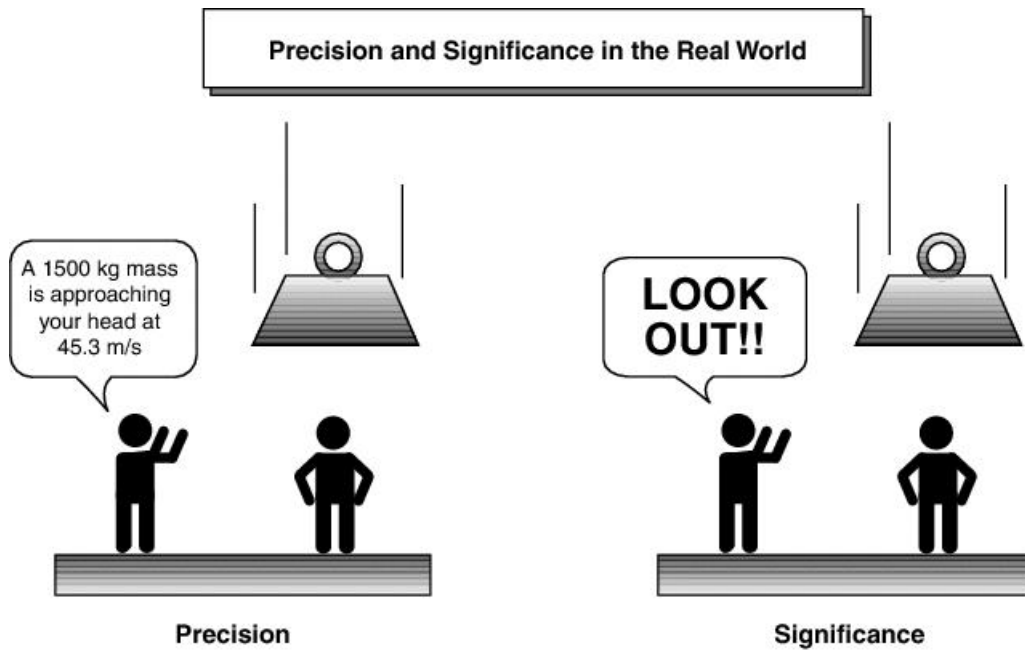

Source: own

Fuzzy logic is more adaptable to the real world. Instead, of using fixed values, a range of semantic values can be better adapted to human expressions, and can enable the assessment of inferential quality factors (e.g. much, little, very). Fuzzy logic also makes use of set operations, including unions, intersections, differences, negations etc. to carry out the treatment of information and to arrive at a result.

In Figure 9, temperature is expressed with three labels that correspond to the trapezia below. Each label has a range of values, wherein there are ranges of certainty. For example, on the left side of the figure, '1' is the maximum certainty value of 'cold.' However, as we transition to the right, there is clearly an uncertainty region (a.k.a. 'fuzzy' region) between 'cold' and 'warm' [7,8]. This uncertainty can be used to our advantage.

Figure 9: Second fuzzy-logic example.

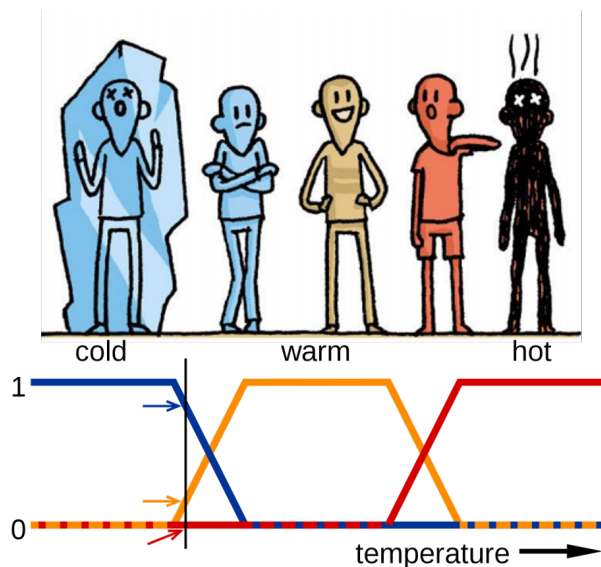

Source: own

Fuzzy logic also makes use of heuristic rules (e.g. IF (antecedents) THEN (consequent)). For example,

- IF it is very cold, THEN turn up the heating a lot.
- IF it is not too cold, THEN turn up the heating a little.
- IF it is very hot, THEN turn off the heating.

This technique not only helps efficiently control processes, it also is best suited to deliver proper alerts that users can understand.

3. Methodology

The first step will entail the design and construction of the selected greenhouse structure. We must review the literature regarding the types of crop to be implemented inside, the sizes of the beds, the dimensions of the irrigation system and the space requirements for the

sensors, actuators, boxes and connections.

The different sensor networks will then be selected and implemented, emphasizing the control of irrigation, illumination and humidification. Moreover, temperature and humidity monitoring at the interior of the structure will be critical. To control the physical magnitudes according to the measured variables, we will select actuators to manage the irrigation, lighting and humidification systems. For these purposes, different models having varying characteristics should be studied, and the different types of valves and pumps will be examined. For most lighting requirements, bulbs or LEDs are used. In the case of humidity, nebulizers are commonly used. However, owing to budget and size limitations, a homemade humidifier will be implemented.

We will then design a drip irrigation system, which is the most appropriate for crops under cover. We should avoid surface irrigation because of its difficult controllability and low accuracy. Furthermore, pressure irrigation would cause increased humidity, enabling the emergence of fungi and crop diseases. Considering the possible sizes and varieties to be sown in the interior, we will perform calculations corresponding to the hydric needs of the potential crops, which must be similar, given that the laminar water will be applied the same throughout.

Finally, we will complete the greenhouse construction, characterize and validate the sensors, and monitor the actuators. We will then be required to make subsequent corrections while designing a basic Arduino fuzzy controller, where the databases, graphs and reference values will be located. Then, we can grow some plants.

Figure 10: Structural design.

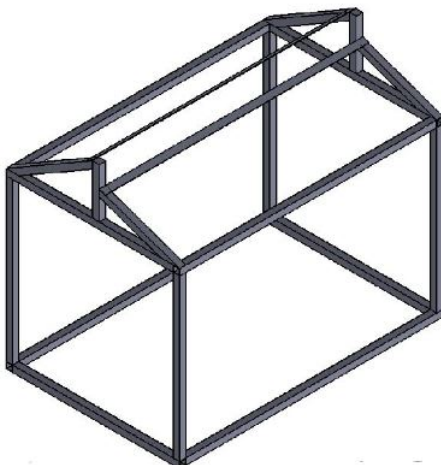

Source: own

4. Analysis and results

This section accounts for the accomplishment of greenhouse construction according to Section 3's methodological plan. Figure 10 shows the design based upon the physiological characteristics of small crops of oregano, parsley and thyme. We observed known root growth patterns and calculated the maximum altitude and water requirements. We constructed a base of white acrylic with walls and roof of transparent acrylic, both complying with given resistance indices to avoid bending and to resist other possible adversities.

On the base, we arranged a support a cover and protect all internal elements (i.e. cables, tanks, actuators, control box). This cover was equipped with holes for cables, hoses and other items, including the humidifier outlet. The entire structure was covered with white tape to mask excess cables and to support the LDR, the LED tape and the ventilation engine.

Figure 11 shows the connections of each system element and the controller, at which the data will be processed. The substrate is 50 % carbon slag, 25 % rice husk and 25 % coconut fibre, which is a good mixture with adequate porosity and good moisture retention. The mixture is also inert and does not provide nutrients to the plants. We applied humus as an organic fertilizer.

The yield curve of the substrate allows us to well-predict the values of temperature and humidity needed in terms of irrigation. The point permanent of wilting occurs with humidity at 15 bars, and the point of field capacity is 0.3 bar.

Figure 11: DHT11, LDR, Soil Moisture, H-bridge connection, [4].

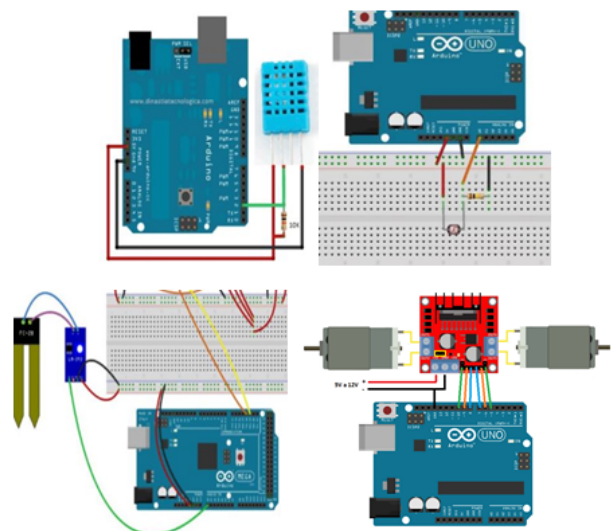

Figure 12: Moist, humidity and temperature sensors, hoses and stakes (left), light sensor (right).



Source: own

We added the upper part of the LDR sensor to measure the presence of light, as shown in Figure 12. Under this, we located the LED ribbon directly on the beds of cultivation, selected to capture the largest amount of ambient light. In the lower part (on the acrylic), the beds of the culture were situated amid the irrigation system, as seen in Figure 13. The humidity and ambient temperature sensors were placed close to the biomass, where accurate measurement is critical. The soil humidity sensors were buried under the substrate. The irrigation system provided eight integrated drippers, two per bed. Each provided a flow of 2.3 lph and was linked to a main line.

The code was divided into two parts. The first contained the initialization libraries, where the pin-out definitions were coded as inputs and outputs. We then organized and configured the pins. To create the fuzzy controller, we created labels and levels for each variable to be controlled. Then, the fuzzy object was defined, wherein the variables would enter and the signals would exit to the actuators. The second part contained the set of rules used to govern the fuzzy logic, allowing us to convert observations into actions, as shown in the theoretical frame, and to finally deliver information back to the user about the state of the system.

Figure 13: Irrigation system.

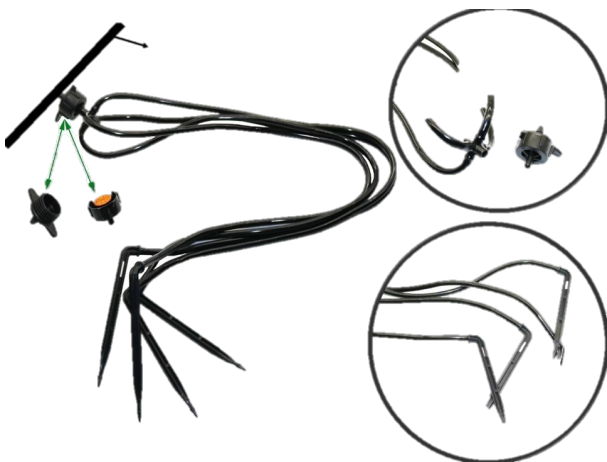

Source: own

With all construction completed, as shown in Figure 14, we programmed the sensors.

Figure 14: Automated greenhouse.



Source: own

As seen in the behaviour graphs of Figures 15-17, the controller functioned suitably for humidity and temperature. The measurement of light, however, revealed oscillations, inaccurately generated with values of output current. Thus, specialised equipment will be required to correct this.

Figure 15: Humidity behaviour.

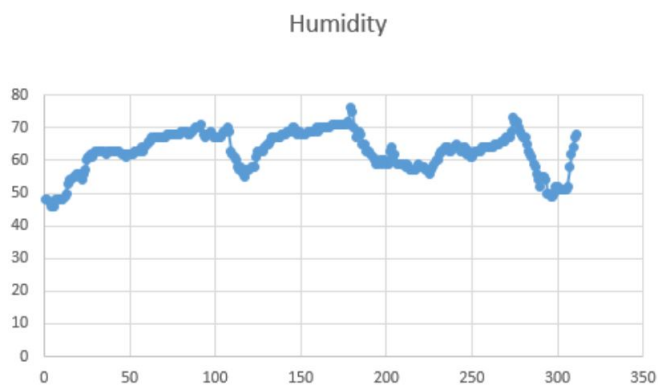

Source: own

Figure 16: Temperature behaviour.

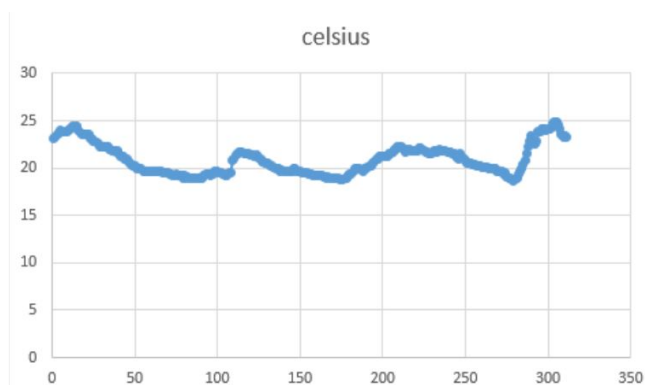

Source: own

5. Discussion

Owing to programming problems and time constraints, it was not possible to implement fuzzier rules for more sophisticated variable fusion, such as temperature-to-humidity, which could be used to obtain psychrometric calculations. However, the sensor locations were optimal and were selected from solid criteria based on critical system characteristics, which allowed the controller to receive accurate measurements.

Additionally, the location of the actuators provided opportunities to level the measured variables much faster than we would have otherwise been capable. Owing to inconveniences during the testing phase, it was not possible to implement the screen for viewing the fused data. However, this was accounted, and future revisions will be made to further develop the presentation using linguistic labels that represent the current state of variables within the greenhouse.

Figure 17: Light behaviour.

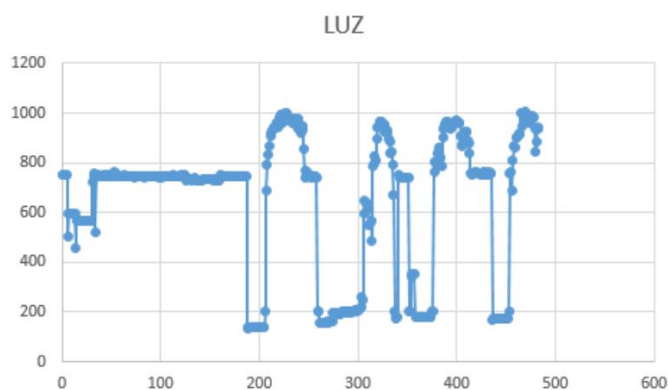

Source: own

At farming levels, the use of soil-moisture sensors is key for proper and accurate irrigation application, and they are useful for detecting contaminants (e.g. salts). In addition to facilitating the analysis of meteorological variables (e.g. grazing days), such sensors could indicate whether the soil is suitable for this and other purposes.

We observed that sensor movement or replacement could interfere with data collection. Thus, it would be better if the sensors were left alone in their samples during the entire test. It is also necessary to consider that each sensor has its own measurement range, which can affect analyses and calculations.

6. Conclusions

The work team developed and implemented a greenhouse prototype with which it was possible to control and monitor several fluctuating physical magnitudes of three crops of aromatic plants. Owing to the implementation of different sensors for soil-moisture measurement, it was possible to monitor several reference points to calibrate the sensors according to the behaviours of the drying curve. The implementation of new controllers based on fuzzy logic will allow a significant advance in agriculture using process controls and analytical tools. The design of this custom

greenhouse will allow for the advanced control of environments where plant growth is otherwise not suitable.

References

- [1] J. I. Montero, "Desarrollo de estructuras para invernaderos", *Cuadernos de Estudios Agroalimentarios (IRTA)*, no. 3, pp. 45-70, 2012.
- [2] EcuRed, "Drenaje agrícola", 2019. [Online]. Available at: https://www.ecured.cu/Drenaje_agr%C3%ADcola
- [3] Infoagro, "Control climático en invernaderos", 2018. [Online]. Available at: https://www.infoagro.com/industria_auxiliar/control_climatico.htm
- [4] L. Llamas, "Medir temperatura y humedad con Arduino y sensor dht11-dht22", 2016. [Online]. Available at: <https://www.luisllamas.es/arduino-dht11-dht22/>
- [5] Y. Edan, S. Han, and N. Kondo, "Automation in agriculture", In Springer handbook of automation, Springer, Berlin: Heidelberg, 2009, pp. 1095-1128. https://doi.org/10.1007/978-3-540-78831-7_63
- [6] J. D. Rodríguez, N. F. Sanabria, and A. Chacón-García, "Temperature and humidity control for edible mushrooms' crop shiitake", *Visión Electrónica*, vol. 6, no. 1, pp. 104- 114, 2012. <https://doi.org/10.14483/22484728.3753>
- [7] J. Calderón-Acero, and I. V. Parra-Garzón, "Controllers fuzzy in microcontrollers: software for design and implementation", *Visión Electrónica*, vol. 4, no. 2, pp. 64-76, 2010. <https://doi.org/10.14483/22484728.273>
- [8] H. E. Espítia-Cuchango, L. C. Morales-Laguado, and J. J. Soriano-Méndez, "Design and simulation of a fuzzy controller for a dc motor based on Boolean relations", *Visión Electrónica*, vol. 4, no. 1, pp. 12-22, 2010. <https://doi.org/10.14483/22484728.263>